



770C-SYS-WP 4 HEAD
UNDERCOVER VEHICLE STROBE SYSTEM
EMERGENCY WARNING LIGHT POWER SUPPLY
WITH FOUR REMOTE STROBE LAMPS

IS0399-01
02-24-2003

INSTRUCTION SHEET

SAFETY NOTICES
WARNING

Failure to follow all safety precautions and instructions may result in property damage, serious injury, or death to you or others.

**SAFETY MESSAGE TO INSTALLERS, USERS,
AND MAINTENANCE PERSONNEL**

It is important to follow all instructions shipped with this product. This power supply is to be installed by a trained installer who is thoroughly familiar with electrical wiring techniques, including manufacturers guidelines for mobile vehicular applications, the national electrical code and local codes.

This power supply generates 600 volts. NEVER work on this power supply or lighting system before removing input power. WAIT 10 MINUTES AFTER REMOVING INPUT POWER BEFORE ATTEMPTING ANY SERVICE ON THIS SYSTEM.

The selection of the mounting location for this device, its controls and the routing of the wiring is to be accomplished under the direction of the engineer in charge.

The 770P-1228-WP weighs approximately 3.5 pounds. For mobile vehicular applications, the installer must find a safe mounting location so that in the event of an accident the power supply cannot become loose within the passenger compartment of the vehicle and potentially cause impact to a passenger.

Listed below are other important safety instructions and precautions.

- Read and understand all instructions before beginning any installation.
- DO NOT connect power to this device before completing the installation. If installing in a vehicle, disconnect the battery of the vehicle before beginning installation.
- After installation, ensure that all mounting hardware is tightened, all electrical joints are tight, and all connections are properly seated.
- After installation and testing is complete, provide a copy of these instructions to all operating personnel.
- TEST THE SYSTEM REGULARLY TO ENSURE THAT IT IS OPERATING PROPERLY.

WARRANTY

This product is covered by TOMAR's standard warranty except that the warranty period is extended to 5 years for the power supply.

INSTALLATION

1. UNPACKING

After unpacking the strobe system, examine it for damage that may have occurred in shipping. If the equipment has been damaged, do not attempt to install or operate it. File a claim immediately with the carrier stating the extent of the damage. Carefully check all envelopes, shipping labels, and tags before removing or destroying them.

Carefully check contents of the shipping package and verify that you have received the following items.

Each 770C-SYS-WP contains:

Power	QTY	DESCRIPTION
	1	Model 770P-1228-WP Strobe Power Supply with Installation Instructions & Connector Kit
	1	770C-SYS-WP Installation Instructions
	2	Cable Kit 15C
	2	Cable Kit 20C
Lamps	QTY	DESCRIPTION
	4	4701-WP Strobe Lamps
	or	
	4	470-RLWP Strobe Lamps
	4	M1039 Gasket for 470-RL Strobe Lamp
	12	H0486 8-18 X 3/8 Philips Hex Washer Screws

**UNDERCOVER STROBE LIGHT
INSTALLATION**

Remove the front and rear turn signal housings from the vehicle, consult the owners manual for proper removal of the turn signal housings.

Carefully determine the desired strobe lamp installation location. When possible, place the strobe insertion hole through a flat surface of the turn signal assembly and such that the strobe lamp will be in an upright position. Before modifying the turn signal housings verify that the strobe lamp cable will not obstruct the re-installation of the turn signal housing.

When installing a 4701-WP strobe lamp, drill a 1.00 inch diameter hole and work the 4701-WP rubber friction mount base firmly into the hole. An automotive grade silicon adhesive may be used to seal the 4701-WP lamp.

When installing a 470-RLWP strobe lamp, drill a 1.375 inch diameter insertion hole and three mounting screw holes with a # 28 or 9/64 drill bit, using the M1039 gasket as a template.

An alternating flash pattern is achieved by connecting lamps # 1 through # 4 around the vehicle in either a clockwise or counter-clockwise direction. Route the lamp and power cables such that they are not exposed to sharp or jagged edges.

Refer to the owners manual and re-install the front and rear turn signal housings.

WIRING DIAGRAM

FRONT TURN SIGNAL ASSEMBLIES

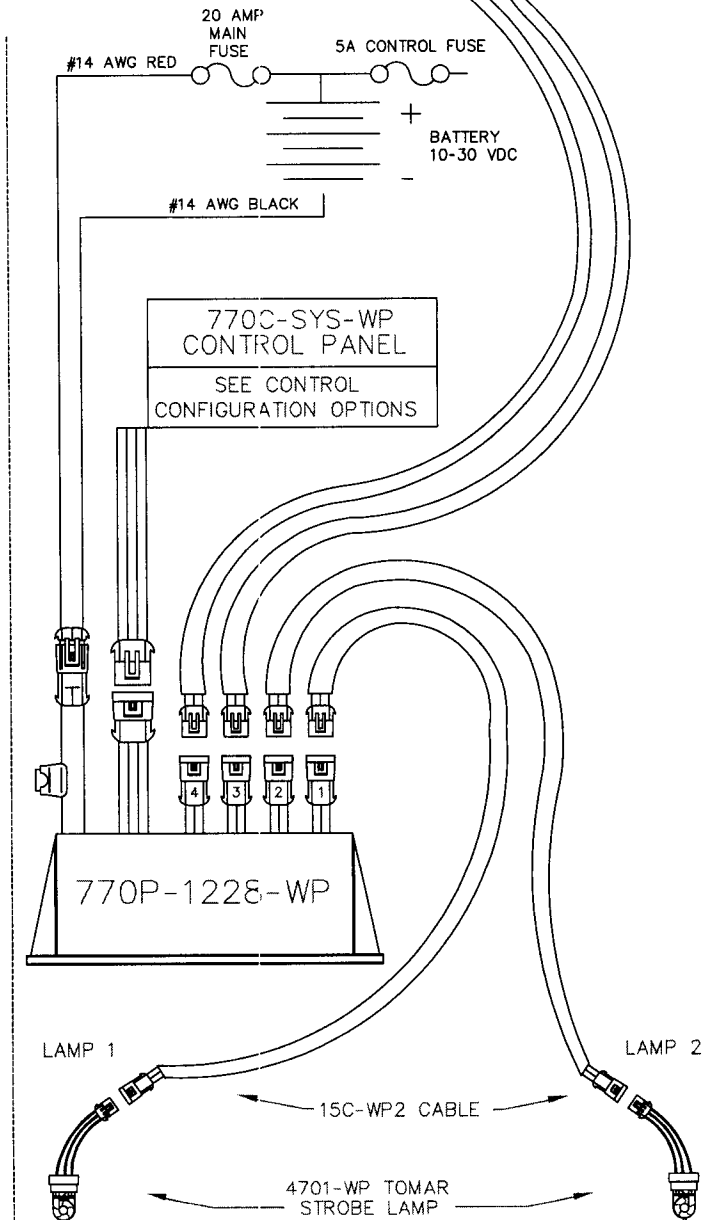
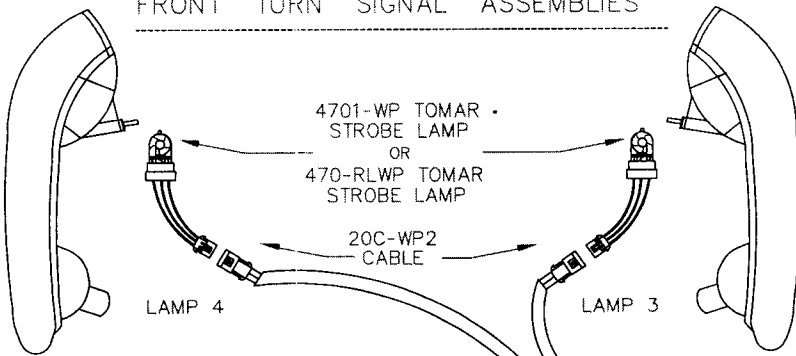

REAR TURN SIGNAL ASSEMBLIES

PARTS

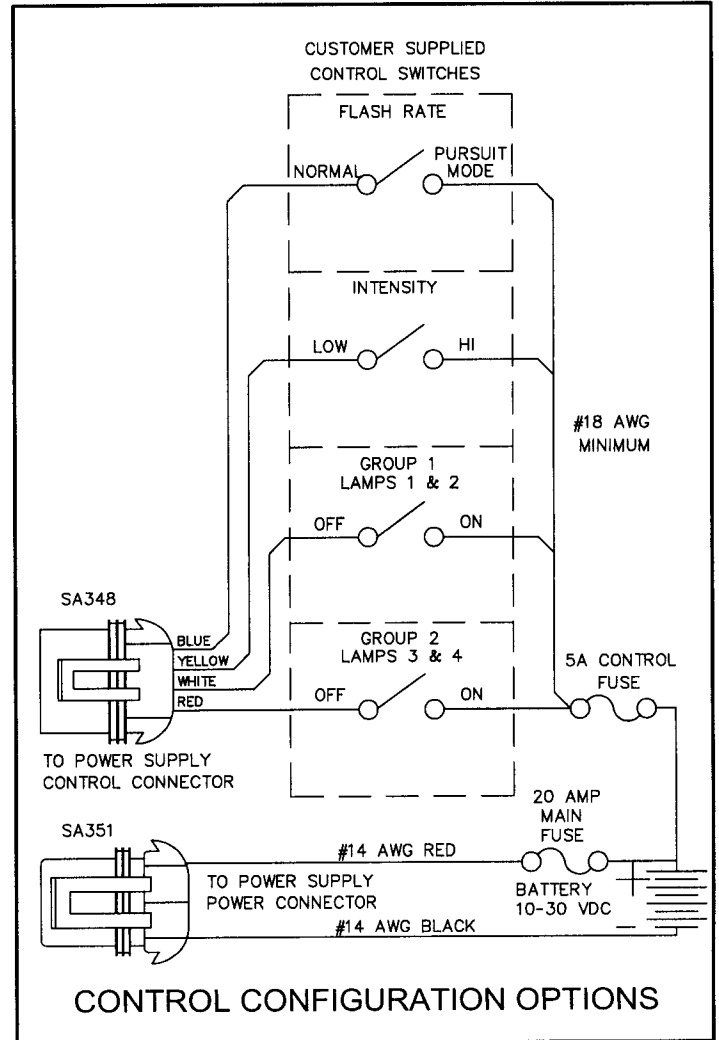
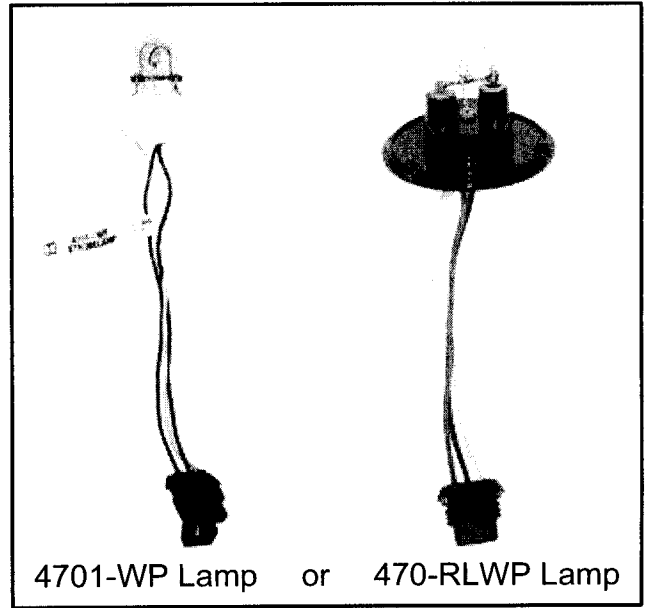

CONTROL CONFIGURATION OPTIONS

TOMAR Electronics, Inc.

2100 West Obispo

Gilbert, Arizona 85233

(480) 497-4400 (800) 338-3133

FAX (480) 497-4416 (800) 688-6627

E-mail: sales@tomar.com

www.tomar.com

