

LED LIGHTING

930L-3203

LED LIGHTBAR

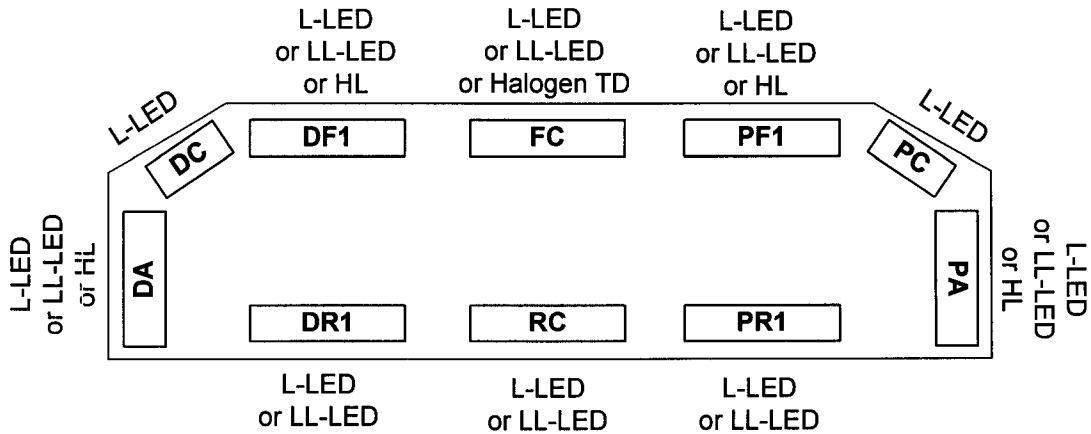

L-LED - Single Element LED Warning Lamps
LL-LED - Dual Side-by-Side Element LED Warning Lamps
HL - Side-by-Side LED and Halogen Lamp

LIGHTBAR OPTIONS

- Alley Lights - Rect-37HL in DA & PA
- HL Halogen-LED split Lamp Takedown DR1 / PR1

FC Position - Select One Only

- 930-PRE2-1C - Single Head Strobe Preemption Emitter (Coded PRE Optional) in FC
- L-LED or LL-LED or Halogen Lamp for Takedown in FC

NFPA & SAE J2498 Zone A Upper Applications - select from compatible configurations.

- Qty 2 - **ALL RED
- Qty 2 - ½ Red ½ Blue
- Qty 2 - ALL RED (or ½ Red ½ Blue), with WHITE FC [FC - optional PRE2-1C]
- Qty 2 - ALL RED, with WHITE DC & PC

Note:

Lamps DA & PA will contribute to Upper Zones B & D respectively.

Rear facing lamp positions may be Blank, or Red, Blue or Amber - consideration of Upper Zone C contribution, by some or all rear facing lamps, to be determined by installer.

LED Lamps may be clear or colored lens.

**A pair of 930L-3203 lightbars may be rotated into zones B & D respectively, not to exceed 30 degrees. If rotated between 25 and 30 degrees - a pair of 930L-3203 (All Red, including DA/PA) provides coverage for Zones A, B & D Upper.

Refer to Tomar NFPA guidelines for additional system information.

Revision: 11-24-2004

5 YEAR WARRANTY!

This product is covered by TOMAR's standard warranty except the warranty period is extended to 5 years.

2100 WEST OBISPO AVE.
GILBERT, AZ 85233



PHONE: 800-338-3133
FAX: 800-688-6627