



## 3000 ML/RML POWER STROBE®

### Industrial Heavy Duty Warning Light

The model 3000 family of single flash strobe lights is designed for heavy duty industrial use in steel mills and large manufacturing plants. The ML version is a 360° self contained unit consisting of a strobe lamp and Lexan® lens assembly mounted on a NEMA 4 enclosed power supply. The RML version consists of a lamp assembly and remote power supply mounted in a NEMA 3R rain tight enclosure.

The 250VDC 3000 series strobe has a flash rate of 60 flashes per minute and light intensity of 425 effective candlepower. It is available in six lens colors (amber, blue, clear, green, purple, and red). Each strobe contains a built-in RFI filter to protect against harmful electrical interference.

- 250 VDC
- NEMA 4X enclosure
- optional stainless steel enclosure
- built-in RFI filters
- 10,000 hour strobe lamp
- polarity protected
- solid state power supply
- optional dome guard
- optional lens dust cover

Lens Colors

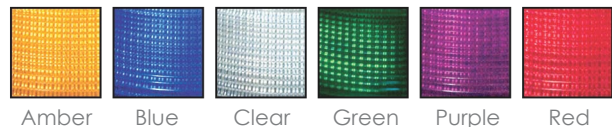

#### Ordering Information

Please specify lens colors and model number when ordering. Available colors are Amber, Blue, Clear, Green, Purple and Red.

Model No.	Description	Voltage/Frequency
3000ML	Power strobe NEMA 4X	250VDC
3000/RML	Remote strobe NEMA 3R	250VDC

# 3000 ML/RML POWER STROBE

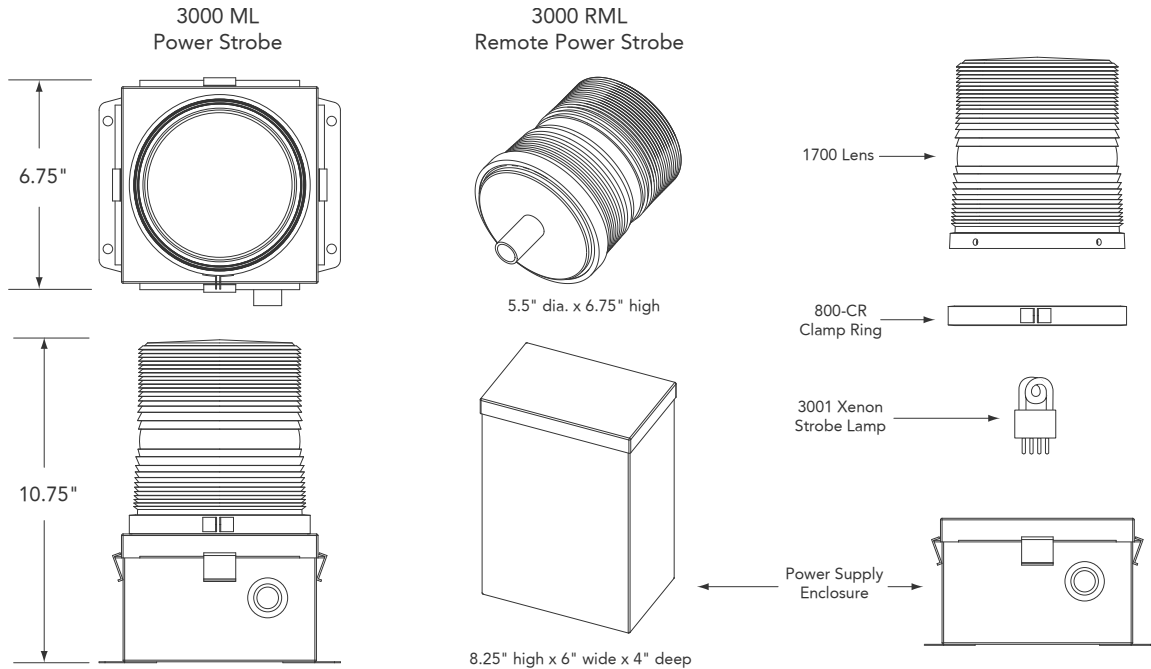

## Specifications

Item	Description
Flash Rate	60 FPM
Light Output	425 effective candlepower
Voltage and Amperage	250VDC -- draws 0.07A average
Power Supply Output	15 Watts -- 10 joules per flash
Size and Weight	ML -- 10.75" tall x 6.75"sq ( 228mm x 171mm) -- weight = 6.5 lbs. (2.94kg) RML -- Power Supply Enclosure -- 8.25" tall x 6" wide x 4" deep ( 209mm x 153mm) Remote beacon = 5.5" dia. x 6.75" tall (139mm x 171mm) Total weight = 7lbs. (3.17kg)
Operating Temperature	-25°c to 70°c

## Available Options

NOTE: All "/" options are factory installed only.

Model No.	Description
/SS	Stainless steel enclosure
/GP	Heavy duty guard ( for ML version only )
800/1250-DC	Lens dust cover

## Replacement Parts

Model No.	Description
3001	Xenon strobe lamp
1700	Color lens ( please specify color )
3002B	Power supply for 3000 series

## Architect and Engineer Specifications

The visual signaling beacon shall be Tomar model 3000 series or approved equal. The light source shall be a plug-in field replaceable single-flash xenon strobe lamp. The warning beacon shall have a Lexan® lens and be designed to accept a dome guard. Light intensity is to be 425 effective candlepower. The beacon must have the option to be mounted remotely from the power base, and the strobe tube is to be rated at 10,000 hours lamp life. Voltage shall be 250VDC. Strobe light shall be designed to accept a dome guard, lens dust cover, and stainless steel enclosure.