



## 3000, 3200 & 7120R POWER STROBE®

Industrial Heavy Duty Strobe

The model 3000 family of single flash strobe lights is designed for heavy duty industrial use in steel mills and large manufacturing plants. The ML version is a 360° self-contained unit consisting of a strobe lamp and Lexan® lens assembly mounted on a NEMA 4 enclosed power supply. The RML version consists of a lamp assembly and remote power supply mounted in a NEMA 3R rain tight enclosure. The model 7120R hi-power industrial duty double flash strobe light features a remote mounted solid state power supply in a NEMA 4 JIC box and a 1/2" pipe mounted strobe lighthouse with a 360° Lexan® lens and a long life (24,000 hour) strobe lamp, model 6001.

- built-in RFI filters
- solid state power supply
- xenon strobe lamp
- two year warranty on power supply
- one year warranty on lamp
- available in six lens colors

### Ordering Information

Please specify lens colors and model number when ordering. Available colors are Amber, Blue, Clear, Green, Purple and Red.

Model No.	Description	Voltage/Frequency
3000ML	Power strobe NEMA 4	250VDC
3000/RML	Remote strobe NEMA 3R	250VDC
3200ML	Power strobe NEMA 4	120VAC
3200/RML	Remote strobe NEMA 3R	120VAC
3200HP	15 joule strobe NEMA 4	120VAC
3200HP/RML	Remote 15 joule strobe NEMA 3R	120VAC
3300ML	Power strobe NEMA 4	240VAC
3300/RML	Remote strobe NEMA 3R	240VAC
7120R	High power remote strobe NEMA 4	120VAC

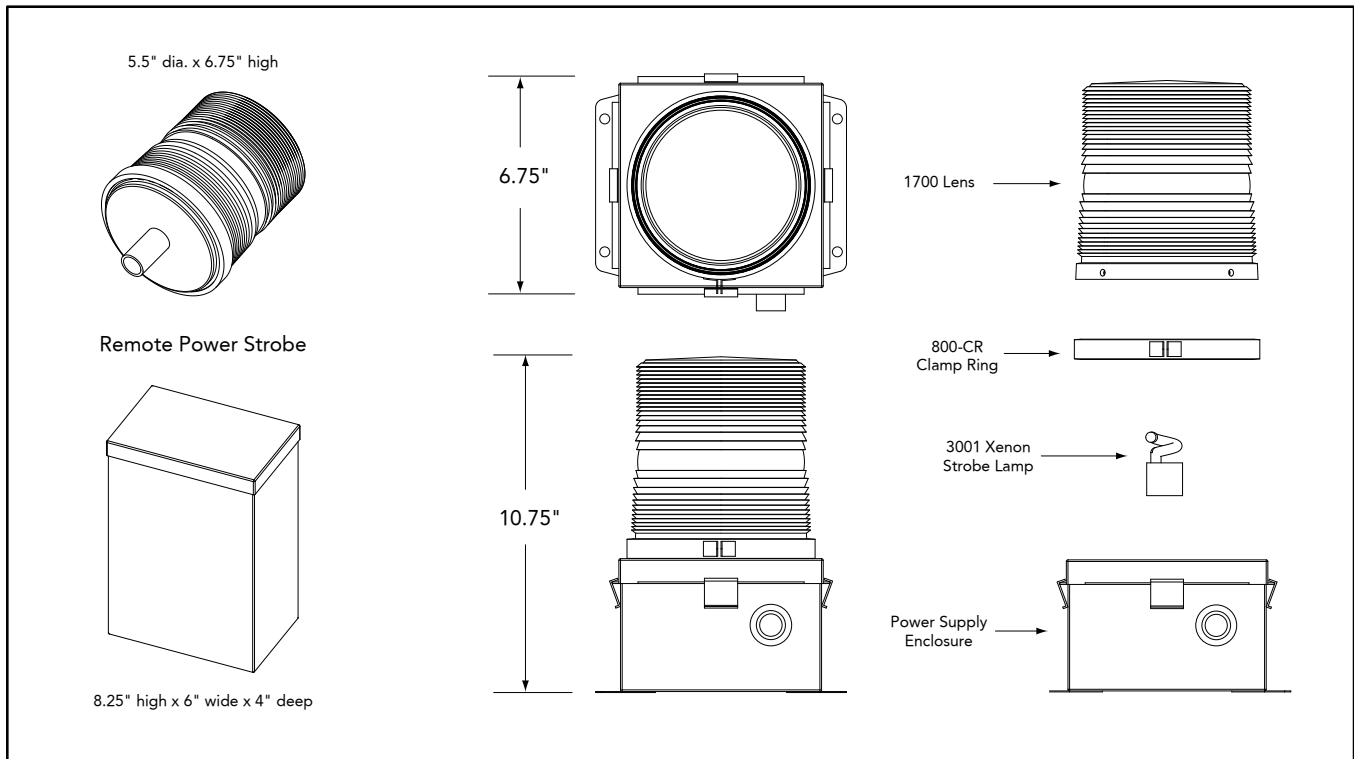

## Specifications

Item	Description
Voltage and Amperage	Model 3000 -- 250VDC -- draws 0.07A average Model 3200 -- 120VAC -- draws 0.17A average Model 3300 -- 240VAC -- draws 0.12A average Model 7120R -- 120VAC -- draws 0.4A average
Power Supply Output	15 Watts -- 10 joules per flash ( ML and /RML units ) 15 Watts -- 15 joules per flash ( HP units ) 26 Watts -- 20 joules per flash ( 7120R )
Flash Rate	85 FPM @ nominal line volts to 60 FPM @ low line volts ( 3000 family ) 40 DFPM double flashes per minute ( 7120R )
Size and Weight	9" tall x 6.75" sq. x 6.5 lbs ( 228mm x 171mm x 2.9kg ) -- ( ML ) 21.4375" tall x 9.875" dia. x 33 lbs ( 544mm x 250mm x 15kg ) -- ( 7120R )

## Available Options

NOTE: All "/" options are factory installed only.

Model No.	Description
/SS	Stainless steel enclosure ( 3000 family only )
/GP	Heavy duty guard ( for ML version only )
800/1250-DC	Lens dust cover

## Replacement Parts

Model No.	Description
3001	Xenon strobe lamp ( models 3000ML, 3000/RML, 3200ML, 3200/RML & 3300ML )
4001	Xenon strobe lamp ( models 3300/RML )
6001	Xenon strobe lamp ( models 3200HP & 7120R )
1700	Color lens ( please specify color )
3002B	Power supply for 3000 series
3004B	Power supply for 3200 series
3200HP-PSA	Power supply for 3200HP & 3200HP/RML
3009A	Power supply for 3300 series