



3200 ML with stainless steel enclosure



## 3200/3300 ML/RML POWER STROBE®

### Industrial Heavy Duty Warning Light

The model 3200 and 3300 family of single flash strobe lights is designed for heavy duty industrial use in steel mills and large manufacturing plants. The ML version is a 360° self contained unit consisting of a strobe lamp and Lexan® lens assembly mounted on a NEMA 4 enclosed power supply. The RML version consists of a lamp assembly and remote power supply mounted in a NEMA 3R rain tight enclosure.

The 120 VAC 3200 and 240 VAC 3300 series strobes have a flash rate of 85 flashes per minute and light intensity of 425 effective candlepower. They are available in six lens colors (amber, blue, clear, green, purple, and red). Each strobe contains a built-in RFI filter to protect against harmful electrical interference.

- NEMA 4X enclosure
- optional stainless steel enclosure
- built-in RFI filters
- 10,000 hour strobe lamp
- polarity protected
- solid state power supply
- optional dome guard
- optional lens dust cover

Lens Colors

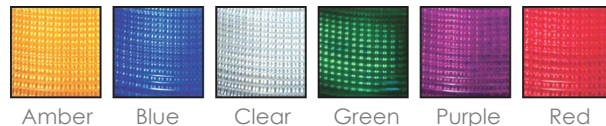

Amber Blue Clear Green Purple Red

#### Ordering Information

Please specify lens colors and model number when ordering. Available colors are Amber, Blue, Clear, Green, Purple and Red.

Model No.	Description	Voltage/Frequency
3200ML	Power strobe NEMA 4X	120VAC
3200/RML	Remote strobe NEMA 3R	120VAC
3300ML	Power strobe NEMA 4	240VAC
3300/RML	Remote strobe NEMA 3R	240VAC

# 3200 3300 ML/RML POWER STROBE

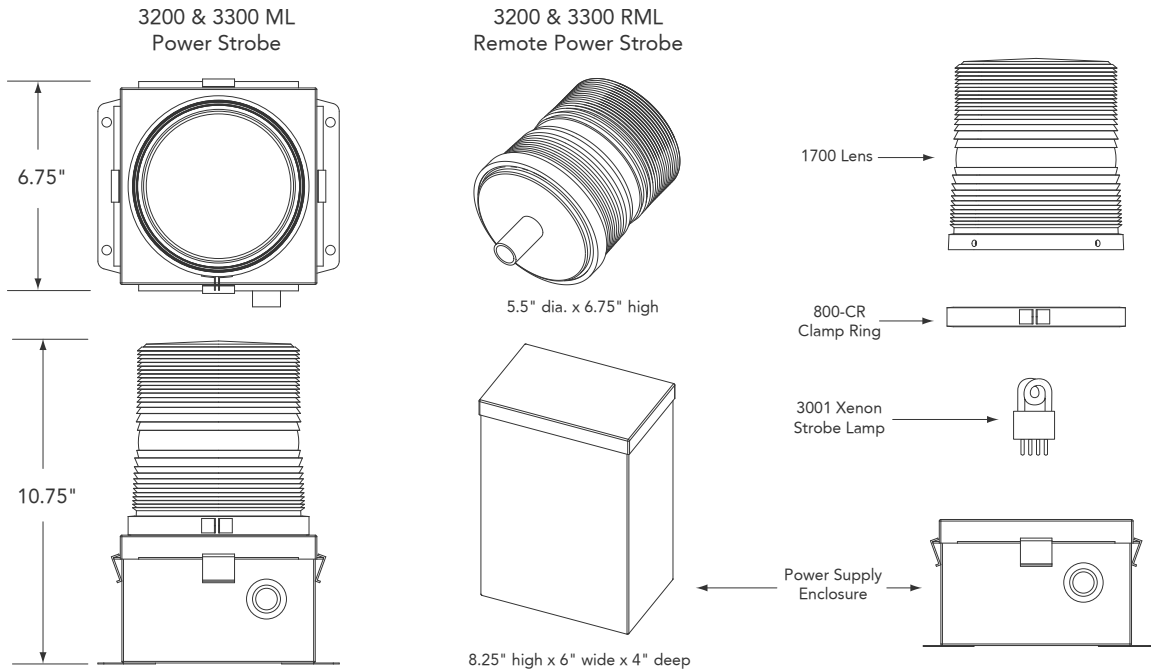

## Specifications

Item	Description
Light Output	424 effective candlepower
Flash Rate	85 flashes per minute @ nominal line volts to 60 FPM @ low line volts
Voltage and Amperage	120VAC -- draws 0.17A average
Power Supply Output	15 Watts -- 10 joules per flash
Size and Weight	ML -- 10.75" tall x 6.75"sq ( 228mm x 171mm) -- weight = 6.5 lbs. (2.94kg) RML -- Power Supply Enclosure -- 8.25" tall x 6" wide x 4" deep ( 209mm x 153mm) Remote beacon = 5.5" dia. x 6.75" tall (139mm x 171mm) Total weight = 7lbs. (3.17kg)
Operating Temperature	-25°C to 70°C

## Available Options

NOTE: All "/" options are factory installed only.

Model No.	Description
/SS	Stainless steel enclosure
/GP	Heavy duty guard ( for ML version only )
800/1250-DC	Lens dust cover

## Replacement Parts

Model No.	Description
3001	Xenon strobe lamp for 3200 series
4001	Xenon strobe lamp for 3300 series
1700	Color lens ( please specify color )
3004B	Power supply for 3200 series
3009A	Power supply for 3300 series

## Architect and Engineer Specifications

The visual signaling beacon shall be Tomar model number 3200 or 3300 series or approved equal. The light source shall be a plug-in field replaceable single-flash xenon strobe lamp. The warning beacon shall have a Lexan® lens and be designed to accept a dome guard. The beacon shall be in 10 joules configuration. Light intensity is to be 425 effective candlepower. The beacon must have the option to be mounted remotely from the power base, and the strobe tube is to be rated at 10,000 hours lamp life. Voltage shall be 120VAC, or 240VAC. Strobe light shall be designed to accept a dome guard, lens dust cover, and stainless steel enclosure.