



801 MINI I™ STROBE

Low Profile - Single Flash
Warning Light

- universal mounting
- built-in RFI filters
- solid state power supply
- 10,000 hour strobe lamp
- five year warranty on power supply
- one year warranty on lamp
- available in six lens colors
- UL listed (where noted below)
- NEMA 4X
- 400 ECP

The model 801 family is a low profile, single flash strobe light featuring universal mounting, low profile 360° Lexan® lens, high efficiency regulated solid state power supply, and heavy duty xenon strobe lamp. All units are polarity protected and have built-in filters to protect against radio interference and spike voltages. The model 801 features a fully potted, Lexan®, multi-purpose mounting base which is vibration and water resistant. The 801 also features a field replaceable plug-in strobe lamp and a state of the art energy storage capacitor for increased intensity.

Lens Colors

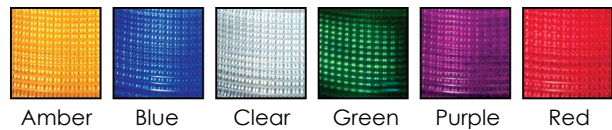

Ordering Information

Please specify lens colors and model number when ordering. Available colors are Amber, Blue, Clear, Green, Purple and Red.

Model No.	Description	Voltage/Frequency
801-110	AC strobe with 10" leads, UL listed	120VAC, 50/60Hz
801LC-110	AC strobe with AC cord set, UL listed	120VAC, 50/60Hz
801LCMB-110	AC strobe, magnetic mount and cord	120VAC, 50/60Hz
801-240	AC strobe with 10" leads, UL listed	240VAC, 50/60Hz
801-1274	DC strobe with 10" leads, 800-FLG	12 - 74VDC
801MB-1274	DC strobe, magnetic mount and 10' coil cord	12 - 74VDC
801MBSC-1274	DC strobe, magnetic mount and 10' straight cord	12 - 74VDC

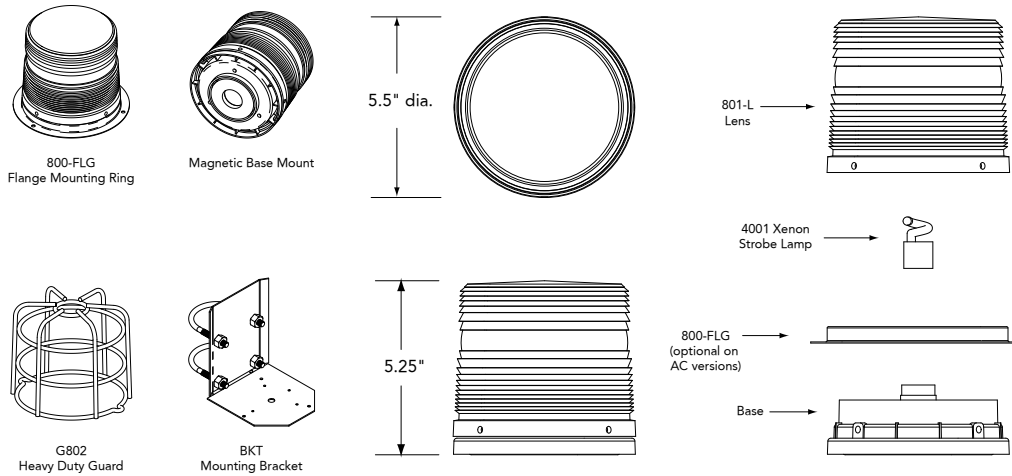

Specifications

Item	Description
Flash Rate	80 to 95 flashes per minute
Light Output	400 candela eff.
Voltage and Amperage	12-74VDC draws 1.25A @ 12V tapering to 0.2A average @ 74V 120VAC draws 0.3A average 240VAC draws 0.3A average
Power Supply Output 11 Watts	8 joules per flash
Size and Weight	5.25" tall x 5.5" dia. x 2.0 lbs (133mm x 140mm x 0.9kg)
Encapsulation	Fully potted in urethane material with no exposure to High Voltage possible

Available Options

NOTE: All "/" options are factory installed only.

Model No.	Description
BKT	Mounting bracket
/LBO-MINILITE	Lens blackout segment 180°
802-03	Lens dust cover
G802	Heavy duty guard
TBO-MAXI	Top lens blackout
800-FLG	Chrome flange mounting ring (standard on DC versions, optional on AC versions)
MINILITE SHIELD	Vinyl, 180° shield

Replacement Parts

Model No.	Description
4001	Xenon strobe lamp
801-L	Color lens (please specify color)
801-110-BASE	120VAC power supply
801LC-BASE	120VAC power supply with AC cord set
801LCMB-BASE	120VAC power supply with magnetic mount and AC cord
801-240-BASE	240VAC power supply
801-1274-BASE	12-74VDC power supply
801MB-BASE	12-74VDC power supply with magnetic mount and coil cord
801MB-SCBASE	12-74VDC power supply with magnetic mount and straight cord

Architect and Engineer Specifications

The visual signaling beacon shall be Tomar model 801 or approved equal. The light source shall be a plug-in field replaceable single-flash xenon strobe lamp. The warning beacon shall have a Lexan® lens and universal mount base. The warning signal must have built-in RFI filters to protect against radio interference and spike voltages. It shall be polarity protected, and have a power supply fully potted in polyurethane. The beacon shall have an 11 watt power supply, and generate 8 joules per flash at 80 to 95 flashes per minute. Light intensity is to be 400 effective candlepower, and voltage ranges shall be 12-74VDC, 120 VAC, and 240VAC. Strobe light shall be designed to accept a dome guard and mounting bracket.