



- wide input voltage range
- universal mounting
- built-in RFI filters
- 10,000 hour strobe lamp
- ten year warranty on power supply
- one year warranty on lamp
- available in six lens colors
- UL recognized (all models)
- lens has hermetic o-ring seal
- NEMA 4X

MICRO IV™

Low Profile - Single Flash Strobe

The MICRO IV strobe family is an enhanced version of the MICROSTROBE featuring a power supply which operates over a wide input voltage range of 12–80VDC or 16–24VAC. The supply has a regulated output so that the lamp brightness and flash remain constant when operated over the rated input voltage range. The power supply is potted in polyurethane for the ultimate in protection from moisture, vibration and exposure to high voltage. The enclosure is all Lexan®, and the plug-in lamp is field replaceable. All units are polarity protected and have built-in filters to protect against radio interference and spike voltages. The MICRO IV is covered by a 10 year warranty. The MICRO IV and its guard are UL component recognized for type E, EE, and ES electric industrial trucks covered by UL standard #583.

Lens Colors



Ordering Information

Please specify lens colors and model number when ordering. Available colors are Amber, Blue, Clear, Green, Purple and Red.

Model No.	Description	Voltage
470SSGP-1280	DC strobe, wall plate mount	12 – 80VDC
470S-1280	DC strobe, surface mount	12 – 80VDC
470SMB-1280	DC strobe, magnetic mount and 6' straight cord	12 – 80VDC
470SMB-1280/CC	DC strobe, magnetic mount and coil cord	12 – 80VDC
485S-1280	DC strobe, screw-in light bulb base	12 – 80VDC
490S-1280	DC strobe, 1/2" female pipe mount	12 – 80VDC
492S-1280	DC strobe, 3/4" IPS slip mount	12 – 80VDC
495S-1280	DC strobe, 1/2" male thread mount	12 – 80VDC

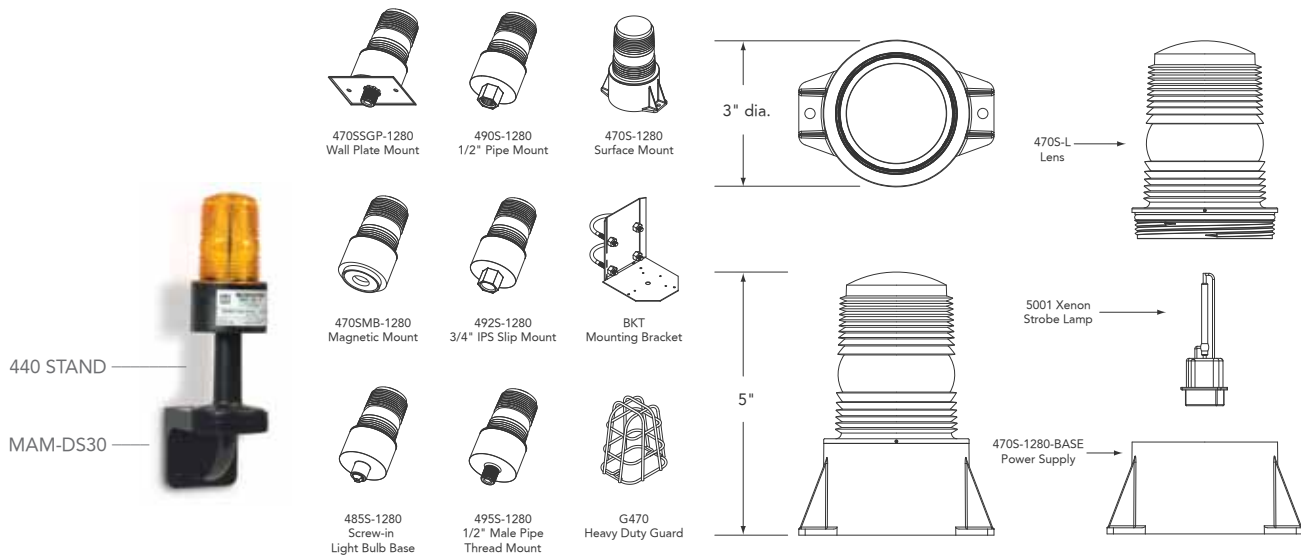

Specifications

Item	Description
Flash Rate	60 to 80 flashes per minute
Light Output	50 effective candlepower
Voltage and Amperage	12-80VDC draws 0.4A average @ 12VDC tapering to 0.05A average @ 80VDC 16-24VAC draws 0.35A average
Power Supply Output 2.7 Watts	1.9 joules per flash
Size and Weight	5" tall x 3" dia. x 0.6 lbs (127mm x 76mm x 0.27kg)
Operating Temperature	-40 C to 65 C
Encapsulation	Fully potted in urethane material with no exposure to High Voltage possible

Available Options

NOTE: All "/" options are factory installed only.

Model No.	Description
G470	Heavy duty guard
BKT	Mounting bracket
LBO-MINI	Lens blackout segment 180°
MICROSHIELD	Vinyl, 180° lens blackout

Mounting Options

Item	Description
BKT	Mounting bracket
440 STAND	Plastic Stand (Thread mount MicroLert models only)
MAM-DS30	Wall mount bracket

Replacement Parts

Model No.	Description
5001	Xenon strobe lamp
4705-L	Colored lens (please specify color)
4705-1280-PSA	12 – 80VDC power supply, surface mount
4705MB-1280-PSA	12 – 80VDC power supply, magnetic mount and 6' straight cord
4705MB-1280/CCB	12 – 80VDC power supply, magnetic mount and coil cord
4855-1280-PSA	12 – 80VDC power supply, screw-in light bulb base
4905-1280-PSA	12 – 80VDC power supply, 1/2" female pipe mount
4925-1280-PSA	12 – 80VDC power supply, 3/4" IPS slip mount
4955-1280-PSA	12 – 80VDC power supply, 1/2" male thread mount

Architect and Engineer Specifications

The strobe light shall be Tomar model number series 470, 480, 485, 490, 492, 495 or approved equal. The light source shall be a plug-in field replaceable single-flash xenon strobe tube. The strobe light must have built-in RFI filters to protect against radio interference and spike voltages. It shall be polarity protected, and have a power supply fully potted in polyurethane. Voltage ranges shall be 12-80VDC or 16-24VAC, 120 VAC, and 240VAC. The strobe light shall be UL listed and of NEMA 4X type weatherproof design with screw-on Lexan® lens.