



**NEOBE® 65 WATT
POWER SUPPLY MODEL 780-1228
EMERGENCY WARNING LIGHT POWER SUPPLY
FOR REMOTE LIGHTHEADS AND LAMPS**

IS0003
REV 05

INSTRUCTION SHEET

**SAFETY NOTICES
WARNING**

Failure to follow all safety precautions and instructions may result in property damage, serious injury, or death to you or others.

**SAFETY MESSAGE TO INSTALLERS, USERS,
AND MAINTENANCE PERSONNEL**

It is important to follow all instructions shipped with this product. This power supply is to be installed by a trained installer who is thoroughly familiar with electrical wiring techniques, including manufacturers guidelines for mobile vehicular applications, the national electrical code and local codes.

This power supply generates 600 volts. NEVER work on this power supply or lighting system before removing input power. WAIT 10 MINUTES AFTER REMOVING INPUT POWER BEFORE ATTEMPTING ANY SERVICE ON THIS SYSTEM.

The selection of the mounting location for this device, its controls and the routing of the wiring is to be accomplished under the direction of the engineer in charge.

The 780-1228 weighs approximately 3.5 pounds. For mobile vehicular applications, the installer must find a safe mounting location so that in the event of an accident the power supply cannot become loose within the passenger compartment of the vehicle and potentially cause impact to a passenger.

Listed below are other important safety instructions and precautions.

- Read and understand all instructions before beginning any installation.
- DO NOT connect power to this device before completing the installation. If installing in a vehicle, disconnect the battery of the vehicle before beginning installation.
- After installation, ensure that all mounting hardware is tightened, all electrical joints are tight, and all connections are properly seated.
- After installation and testing is complete, provide a copy of these instructions to all operating personnel.
- TEST THE SYSTEM REGULARLY TO ENSURE THAT IT IS OPERATING PROPERLY.

INSTALLATION

1. UNPACKING

After unpacking the power supply, examine it for damage that may have occurred in shipping. If the equipment has been damaged do not attempt to install or operate it. File a claim immediately with the carrier stating the extent of the damage. Carefully check all envelopes, shipping labels, and tags before removing or destroying them.

Carefully check contents of the shipping package and verify that you have received the following items.

1 ea. Model 780-1228 NEOBE® Power Supply	
1 ea. INSTALLATION KIT P/N SA429 containing:	
QTY	DESCRIPTION
1	6" - Black Power Lead
1	6" - Red Power Lead
1	6" - 4 Pin Control Connector
1	Install Instructions

If you are missing any of the above items contact TOMAR Electronics Customer Service to request the missing part.

2. MOUNTING

THE 780-1228 WEIGHS APPROXIMATELY 3.5 POUNDS. FOR MOBILE VEHICULAR APPLICATIONS, THE INSTALLER MUST FIND A SAFE, STURDY MOUNTING LOCATION SO THAT IN THE EVENT OF AN ACCIDENT THE POWER SUPPLY CANNOT BECOME LOOSE WITHIN THE PASSENGER COMPARTMENT OF THE VEHICLE AND POTENTIALLY CAUSE IMPACT TO A PASSENGER.

The Model 780-1228 NEOBE® Power Supply is designed for mounting on a sturdy flat surface protected from rain, spills, excessive heat, and physical damage. It may be installed in the trunk of a car, the saddlebag of a motorcycle, or other similar protected location. This device may also be installed in the engine compartment of a vehicle as long as it is mounted to a sturdy, flat surface, as far away from the engine as possible.

Wiring for the device must be protected from cuts, nicks, abrasion, fraying, or any form of accidental exposure to prevent contact with its high voltage output.

Mount the power supply so that its nameplate can be seen by maintenance personnel. It displays an important safety message and advises of the high voltage output.

The Model 780-1228 is potted in polyurethane to prevent any damage from vibration or moisture. Although not intended for unprotected use exposed to direct water, the power supply is very water resistant and condensation or other dripping water will not damage it.

Mounting hardware and installation details are left to the installer.

3. POWER SUPPLY PROTECTION DESIGN

The 780-1228 Power Supply design includes protection against reversed polarity input voltage by incorporating an in-line fuse and a large high amperage internal shunt diode together to form a protection network.

The lamp output ports are protected from external shorts or opens in the lamps or wiring. The power supply will shut itself off if any lamp becomes shorted; no damage will be done to the supply. The supply will restart automatically as soon as the short is removed. The supply also includes output voltage regulators so that its energy storage capacitors will not be damaged if it is activated without lamps connected.

AUTOPOWER LAMP PROTECTION CIRCUIT

AUTOPOWER monitors the number of light heads flashing and sets the individual light head power to a safe level if one or more lamps fails to flash. When both groups are activated in high power and all four lamps are working the power supply output is a minimum of 65 Watts.

The Power Output under various operating modes is approximately as follows:

Low Power - NEOBE - 2 Lamps	10 Watts per Lamp
Low Power - NEOBE - 4 Lamps	5 Watts per Lamp
High Power - HYPER-NEOBE - 2 or 4 Lamps	18 Watts per Lamp
High Power - NEOBE - 2 or 4 Lamps	18 Watts per Lamp

If any lamp should fail to flash, the simultaneous lamp will maintain the same wattage output as when all activated lamps are functioning properly.

4. WIRING

DISCONNECT BATTERY OR OTHER POWER SOURCE BEFORE INSTALLING THE 780-1228.

INPUT POWER

The Model 780-1228 Power Supply is designed to operate from 12 or 28VDC automotive electrical systems. Input power is connected to the power supply via two FASTON type connectors. Mating input power wires are supplied in the install kit. The red wire is positive. The black wire is negative. Refer to the wiring diagram and use 14 AWG size wire minimum to connect the positive and negative power leads to the power supply.

The Model 780-1228 Power Supply is designed to be permanently connected to the vehicle battery through its in-line fuse and any other customer supplied wiring desired. The input battery power does not have to be switched on and off to control the supply. The supply is controlled by applying positive battery voltage to its appropriate control wires as explained below.

This power supply is polarity sensitive and will blow its fuse if connected to the wrong polarity. The 20 AMP input power fuse supplied is part of the polarity protection system. Do not attempt to operate the supply with the fuse bypassed or shorted at anytime as the power supply will be irreparably damaged or destroyed and its warranty voided, if connected to the wrong polarity without the proper size fuse protection.

LAMP CONNECTIONS

CAUTION: LAMP CONNECTIONS CARRY 600 VOLTS. USE EXTREME CAUTION.

Lamps plugged into the Group 1 connectors flash alternately with each other and are activated by applying (+) positive battery to the WHITE wire of the control connector.

Lamps plugged into the Group 2 connectors flash alternately with each other and are activated by applying (+) positive battery to the RED wire of the control connector.

Cabling plugged into the lamp connectors must match the wire color code shown on the nameplate. Failure to observe color-coding will cause short lamp life or failure of the power supply to operate at all.

Lamp A and C flash simultaneously and Lamp B and Lamp D flash simultaneously.

CONTROL WIRING

All functions of the power are controlled by applying positive battery voltage to the appropriate pin on the control connector. A 4 pin mating connector with 6" wire pigtail leads is provided in the Install Kit for this purpose.

Control Connector Wiring

1	Blue Lead	Controls Flash Rate	+Battery Activates HYPER-NEOBE Flash Rate Mode
2	Yellow Lead	Controls Intensity	+ Battery Activates High Intensity
			-or-
			A Photocell connected to either a Negative or Positive input power will automatically reduce intensity for nighttime
3	White Lead	Controls Group 1	+ Battery Activates All Lamps in Group 1
4	Red Lead	Controls Group 2	+ Battery Activates All Lamps in Group 2

5. TESTING

Double check to verify that you have connected the power supply to the proper polarity before applying battery power.

Once you have completed the lamp port, control port, and input wiring, you may reinstall the vehicle battery or reactivate the main power source.

If the main fuse or power input in-line fuse blows when power is applied to the power supply, check the input power wiring polarity. If backwards, simply reconnect correctly and replace the blown fuse.

INSTALLATION IS NOW COMPLETE

WIRING DIAGRAM

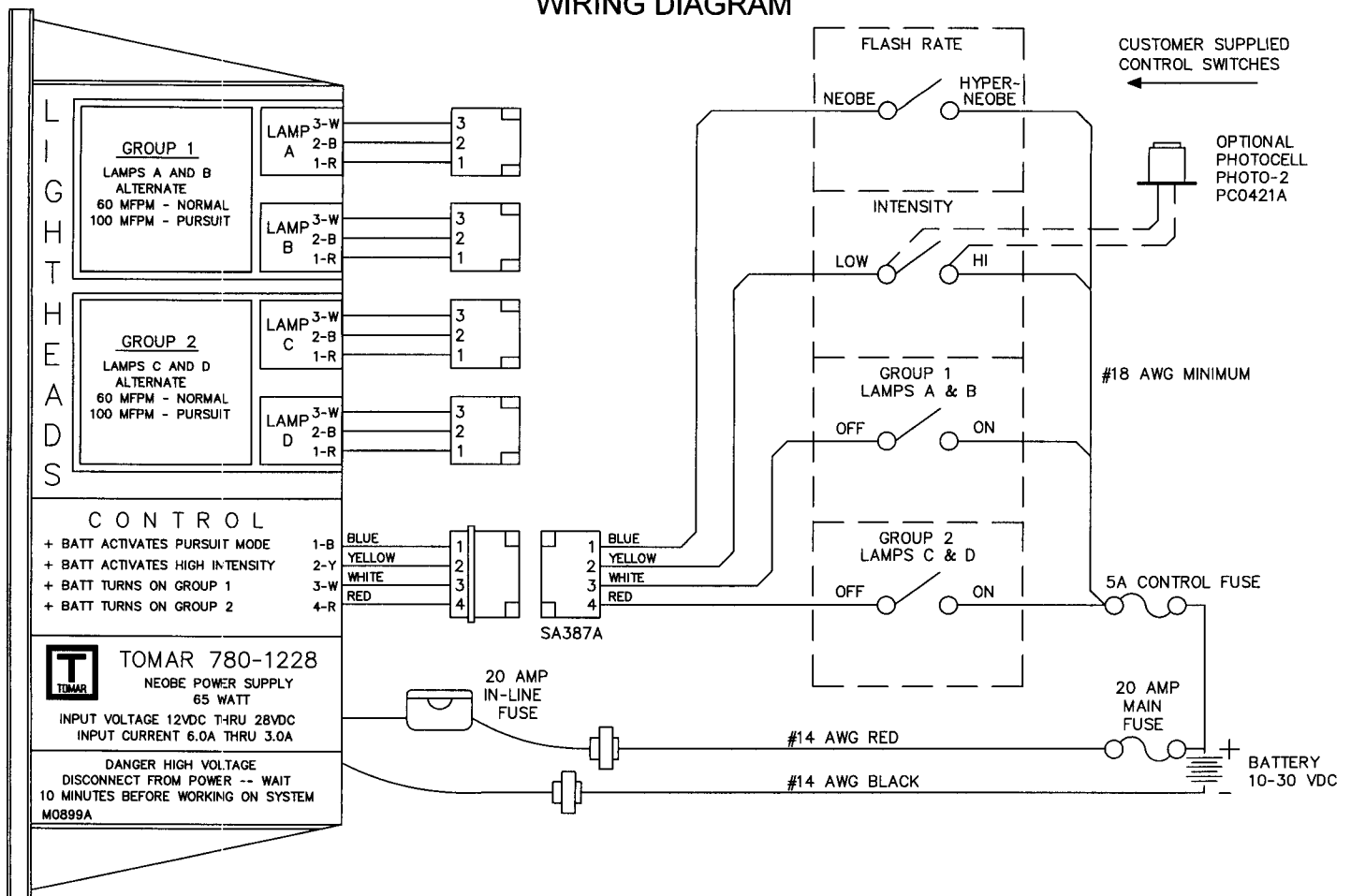

NEOE® POWER SUPPLY OPERATION

Operation of the 780-1228 is very simple due to TOMAR's advanced low current, solid-state power control system. The power supply is designed to have its power input leads connected to the main power source at all times. Normally with no lamps activated, the power supply will enter its standby mode and draw negligible current, similar to the clock in most new cars.

To activate Lamps A and B, close the Group 1 switch.

To activate Lamps C and D, close the Group 2 switch.

To select low intensity, open the intensity switch. For high intensity, close the intensity switch.

To select NEOBE® flash rate, leave the flash rate switch open. To select HYPER-NEOBE close the flash rate switch.

TROUBLE SHOOTING

WARNING

NEOE POWER SUPPLIES ARE HIGH VOLTAGE DEVICES AND CAN STORE LETHAL AMOUNTS OF ENERGY. DO NOT REMOVE OR CONNECT LAMPS OR TOUCH LAMPS WHILE IN OPERATION. DISCONNECT INCOMING POWER AT POWER SUPPLY AND WAIT 10 MINUTES BEFORE BEGINNING ANY SERVICE ON ANY PORTION OF A NEOBE® LIGHTING SYSTEM.

TROUBLE

THINGS TO CHECK

Nothing Works	1) Check battery or power source and main fuse or breaker. 2) Check ground connection.
Power Supply Blows In-Line Fuse	1) Check for reverse polarity on input power connection. 2) Power supply may be defective. Replace with known good unit.
One Lamp Does Not Flash	1) Check lamp by replacing it with a known good lamp. 2) Check lamp cable by plugging a known good lamp directly into the non-functioning light head port.

MAINTENANCE

Replace dead or intermittent lamps immediately.

The 780-1228 NEOBE® Power Supply lighting system should be checked regularly for proper operation.

Lamps connected to the 780-1228 should be kept clean and checked monthly for signs of wear. If the lamp is blackened along more than approximately 30% of its length, or flashes erratically, the lamp should be replaced.

780-1228 NEOBE® POWER SUPPLY SPECIFICATIONS

Size:	7 1/8" X 3 3/4" X 2 1/2" Tall
Weight:	3.5 lbs. Nominal
Construction:	Glass Filled LEXAN® Case, Polyurethane Potting
Power Requirements:	6.0 AMPS AVG at 12.8 VDC 3.0 AMPS AVG at 25.6 VDC
Output Power Rating:	65 Watts Minimum in Hi Intensity NEOBE® Flash Rate, 2 Groups Running
Flash Rate:	60 MFPM/Head NEOBE® Rate Minimum 100 MFPM/Head HYPER-NEOBE Rate Minimum
Flash Pattern:	5 Equal Power Flashes/Multi-flash

780-1228 NEOBE® POWER SUPPLY WARRANTY

TOMAR Electronics, Inc. warrants the product described herein for a period of 10 years under normal use and service from the date of manufacture as marked on the product, that the product will be free of defects in material and workmanship. This warranty does not cover ordinary wear and tear, abuse, misuse, overloading, altered products, or damage caused by the purchaser connecting the unit to the wrong voltage or polarity, or lightning damage.

THERE IS NO WARRANTY OF MERCHANTABILITY; THERE ARE NO WARRANTIES WHICH EXTEND BEYOND THE DESCRIPTION HEREIN. THERE ARE NO WARRANTIES EXPRESSED OR IMPLIED OR ANY AFFIRMATION OF FACT OR REPRESENTATION EXCEPT AS SET FORTH HEREIN.

TOMAR Electronics' sole responsibility and liability, and purchaser's exclusive remedy shall be limited to the repair or replacement at TOMAR's option, of a part or parts not so conforming to the warranty. All products requiring warranty service shall be returned to TOMAR within 10 years of manufacture, shipping prepaid. TOMAR will return repaired or replaced products to the purchaser via prepaid ground transportation. In no event shall TOMAR be liable for damages of any nature, including incidental or consequential damages, including but not limited to any damages resulting from non-conformity, defect in material or workmanship.

TOMAR Electronics, Inc.
2100 West Obispo
Gilbert, Arizona 85233
(480) 497-4400 (800) 338-3133
FAX (480) 497-4416 (800) 688-6627
E-mail: sales@tomar.com
www.tomar.com

